



BANYITONG SCIENCE & TECHNOLOGY DEVELOPING CO.,LTD.

Add: Crossing of Daihe Road and Cailun Road,Hefei,China

Tel: +86 551 6425 5078

Fax: +86 551 6211 3877

E-mail: sales@mimachina.com

Website: www.mimaforklift.com

ELECTRIC REACH TRUCK (STAND ON)

MF12/15/15D

MF20/25/30



BANYITONG SCIENCE & TECHNOLOGY DEVELOPING CO.,LTD.

www.mimaforklift.com





Lift height 5m-8m



MF SERIES REACH TRUCK

- FLEXIBLE OPERATION AND POWERFUL PERFORMANCE -

Electric reach truck has been providing reliable service in warehouses around the world. Especially in narrow conditions, MF series electric reach truck delivers strong performance with its compact structure and excellent lifting capacity.

- 
 Comfortable and beautiful design
 The newly designed control pedal and the ergonomic shock-proof pedal ensure the driving comfort;
- 
 Forks tilt
 The tilting fork makes pallet stacking easier and safer, and it is also easier to separate the fork from the pallet and rack, effectively prevents the goods from falling from the fork.
- 
 Mast system
 The mast has function of moving forward to realize the storage of goods without moving the body, which is more comfortable and safe. The high quality channel steel ensures the load capacity of the reach truck;
- 
 Side pull battery
 Makes battery charging and replacement more convenient.



Small turning radius, flexible steering



HIGH PERFORMANCE

AC drive system, AC motor to provide strong power, more accurate control, more stable operation, high strength vertical gearbox, super long service life, through multi-layer testing of oil pump, cylinder and pipeline, to ensure the high reliability of the hydraulic system.

American AMP waterproof connector and electrical parts of reliable quality, all wires and cables have reliable protection and fixation, greatly reducing electrical failure, high strength loading wheel design to ensure the stability of the reach truck; high strength mast channel steel, high bending resistance improve the strength of mast.

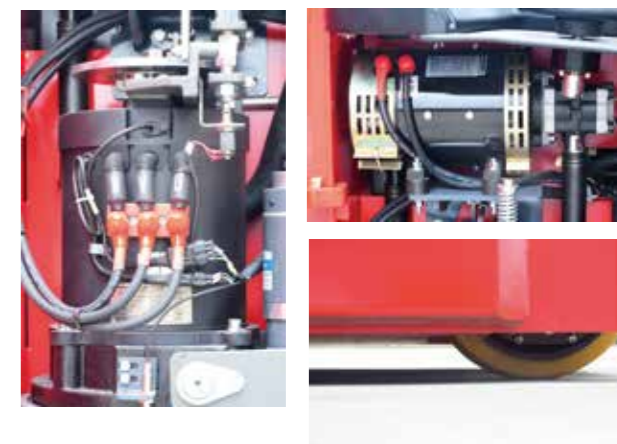

EASY OPERATION

Fully considering the human-machine engineering console, each function button is convenient and easy to operate; The driving position is equipped with cushion to make driving more comfortable.

MORE SAFE

Automatic deceleration function when driving on the curve, it makes driving safer.
Emergency power off switch, when the operation is out of control, it can easily cut off all the power to avoid emergency accident;
Anti-skid braking function prevents the forklift from sliding down when it loses control or runs on a slope;
Strong design for overhead guard, safer operation.



Li-ION

GREEN STORAGE FOR THE FUTURE

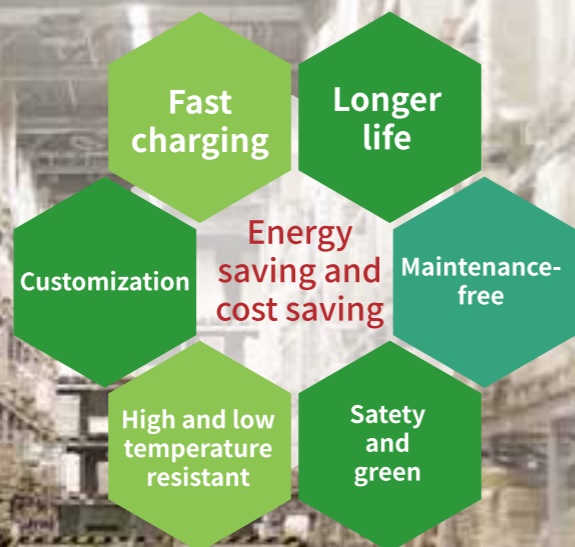

COST SAVING 70%

- It can save much using cost, the electricity costs only take half to one-third of fuel cost;
- The maintenance costs of lithium ion battery forklift just take one-third of combustion forklifts;

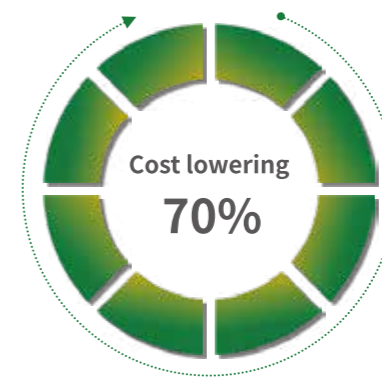
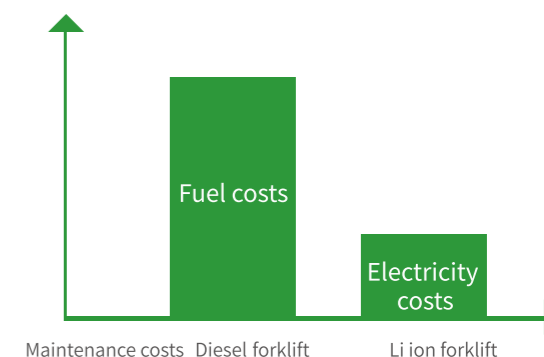
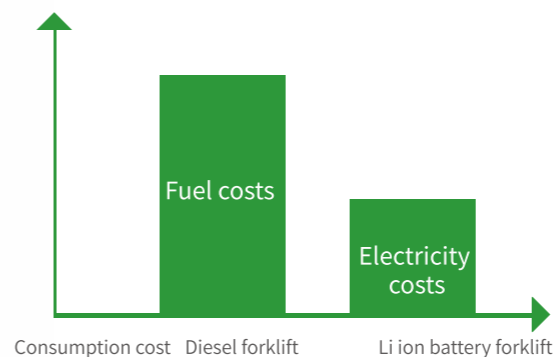

Comparison of MIMA 3T li-ion forklift and diesel forklift

	Consumption	Cost per hour	Cost of one working day (8 hours)	Annual costs (21 days per month)
Diesel forklift (3T)	6.1L	38.4CNY (6.3CNY/L)	307.4CNY	77474.9CNY
Lithium battery forklift (3T)	7.7kwh	7.7CNY (Industrial electricity 1CNY/kwh)	61.6CNY	15523.2CNY

Standard					
1.1 Brand		MiMA	MiMA	MiMA	MiMA
1.2 Model		MF12 (Duplex mast)	MF12 (Triplex full free mast)	MF15D (Duplex mast)	MF15D (Triplex full free mast)
1.3 Power type		Battery	Battery	Battery	Battery
1.4 Operation type		Stand on	Stand on	Stand on	Stand on
1.5 Rated capacity	Q (kg)	1200	1200	1500	1500
1.6 Load center	C (mm)	500	500	500	500
1.7 Front overhang	x (mm)	140	140	140	140
1.8 Wheelbase	y (mm)	1270	1270	1345	1345
Weight					
2.1 Service weight (incl. battery)	kg	2000	2250	2100	2350
2.2 Axle capacity with no load, drive side/load side	kg	/	/	/	/
2.3 Axle capacity with full load when fork forward, drive side/load side	kg	/	/	/	/
2.4 Axle capacity with full load when fork backward, drive side/load side	kg	/	/	/	/
Wheel					
3.1 Wheel type		PU	PU	PU	PU
3.2 Load wheel	mm	Φ 210 × 85	Φ 210 × 85	Φ 210 × 85	Φ 210 × 85
3.3 Drive wheel	mm	Φ 230 × 110	Φ 230 × 110	Φ 230 × 110	Φ 230 × 110
3.4 Auxiliary wheel	mm	Φ 180 × 76	Φ 180 × 76	Φ 180 × 76	Φ 180 × 76
3.5 Number of wheels, front/rear(x=drive wheel)		2/1 x+2	2/1 x+2	2/1 x+2	2/1 x+2
3.6 Wheel tread, drive side	b10 (mm)	615	615	615	615
3.7 Wheel tread, load side	b11 (mm)	999	999	999	999
Size					
4.1 Fork tilt	α / β (°)	3/5	3/5	3/5	3/5
4.2 Mast closed height	h1 (mm)	2080	2080	2080	2080
4.3 Free lift height	h2 (mm)	/	1480	/	1480
4.4 Lift height	h3 (mm)	3000	4500	3000	4500
4.5 Mast extended height with load-backrest	h4 (mm)	3960	5460	3960	5460
4.6 Overhead guard height	h6 (mm)	2250	2250	2250	2250
4.7 Stand board height	h7 (mm)	300	300	300	300
4.8 Overall length	l1 (mm)	2078	2106	2078	2106
4.9 Overall width	b1/b2 (mm)	1090 /1000	1090 /1000	1090/1000	1090/1000
4.10 Fork size	l/e/s (mm)	1070 /100 /35	1070 /100 /35	1070/100/35	1070/100/35
4.11 Fork carriage width	b3 (mm)	1088	1088	1088	1088
4.12 Fork outside width	b5 (mm)	222 -750	222 -750	222-750	222-750
4.13 Inner leg width	b4 (mm)	822	822	822	822
4.14 Reach stroke	l4 (mm)	600	570	690	660
4.15 Mast ground clearance	m1 (mm)	80	80	80	80
4.16 Aisle width for pallet 1000*1200mm(C=500mm)	Ast (mm)	2502	2521	2532	2550
4.17 Aisle width for pallet 800*1200mm(C=600mm)	Ast (mm)	2537	2561	2547	2571
4.18 Turning radius	Wa (mm)	1492	1492	1580	1580
Function					
5.1 Driving speed(load/unload)	km /h	7/8	7/8	7/8	7/8
5.2 Lifting speed(load/unload)	mm /s	150 /190	130/190	150/190	100/190
5.3 Lowering speed(load/unload)	mm /s	190 /170	170 /130	190/170	170/130
5.4 Max. gradeability(load/unload)(S2-5min)	%(tan θ)	≤10	≤10	≤8/≤10	≤8/≤10
5.5 Brake type		Mechanical	Mechanical	Mechanical	Mechanical
Drive					
6.1 Driving motor(S2-60min)	kw	2.3	2.3	2.3	2.3
6.2 Lifting motor(S3-15%)	kw	3.5	3.5	3.5	3.5
6.3 Battery voltage/capacity	V/Ah	24/350	24/350	24/420	24/420
6.4 Battery weight	kg	300	300	335	335
6.5 Steering system		EPS	EPS	EPS	EPS
Other					
7.1 Battery replacement type		Side pull	Side pull	Side pull	Side pull
7.2 Lithium battery voltage/capacity (optional)	V/Ah	24/200	24/200	24/200	24/200

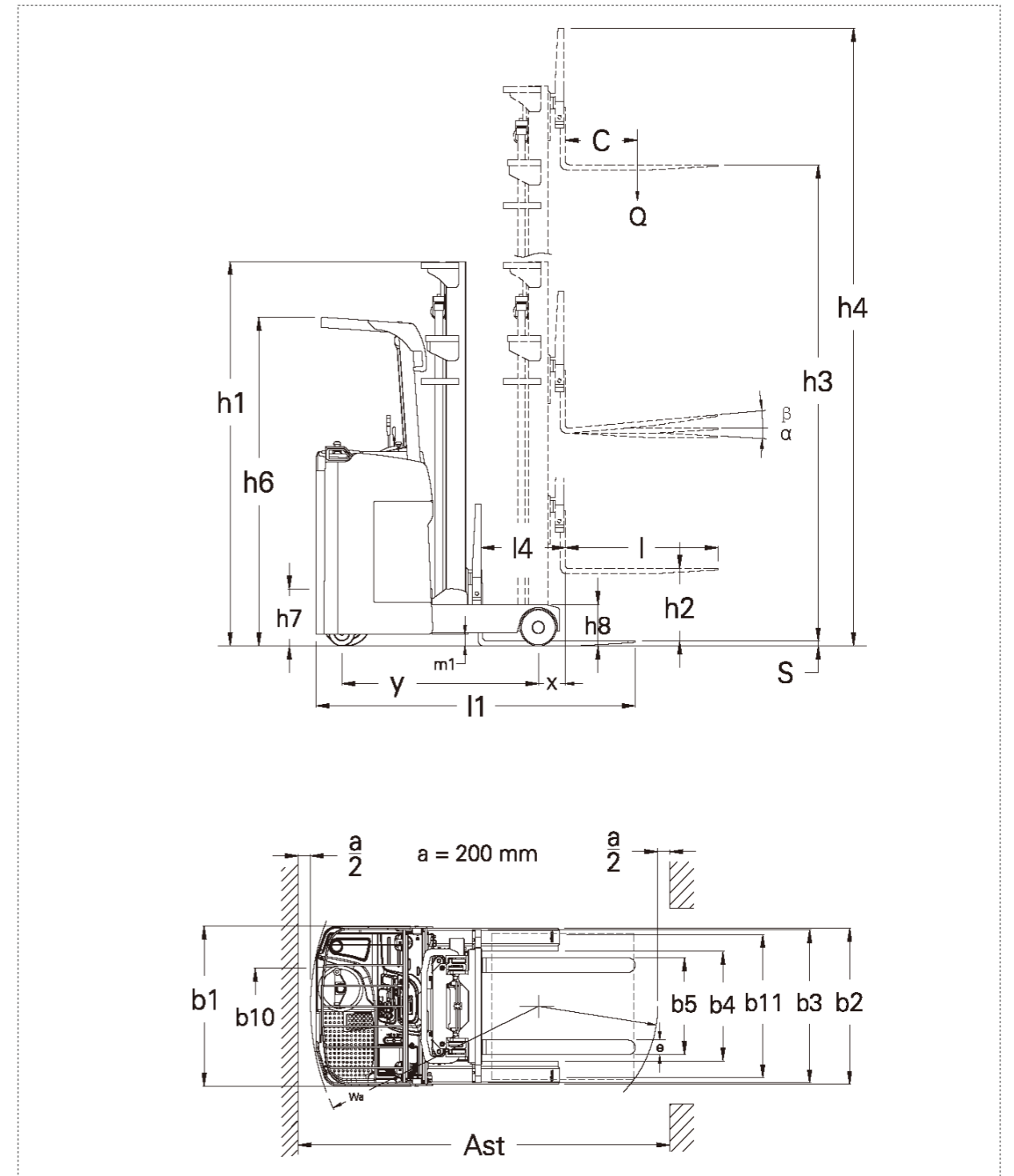

Standard				
1.1 Brand		MIMA	MIMA	MIMA
1.2 Model		MF15 (Duplex mast) Battery	MF15 (Triplex full free mast) Battery	MF20 (Duplex mast) Battery
1.3 Power type		Battery	Battery	Battery
1.4 Operation type		Stand on	Stand on	Stand on
1.5 Rated capacity	Q (kg)	1500	1500	2000
1.6 Load center	C (mm)	500	500	500
1.7 Front overhang	x (mm)	180	180	180
1.8 Wheelbase	y (mm)	1345	1345	1545
Weight				
2.1 Service weight(incl. battery)	kg	2450	2850	2750
2.2 Axle capacity with no load, drive side/load side	kg	/	/	/
2.3 Axle capacity with full load when fork forward,drive side/load side	kg	/	/	/
2.4 Axle capacity with full load when fork backward,drive side/load side	kg	/	/	/
Wheel				
3.1 Wheel type		PU	PU	PU
3.2 Load wheel	mm	Φ 254×104	Φ 254×104	Φ 254×104
3.3 Drive wheel	mm	Φ 343×108	Φ 343×108	Φ 343×108
3.4 Auxiliary wheel	mm	Φ 180 × 76	Φ 180 × 76	Φ 180 × 76
3.5 Number of wheels, front/rear(x=drive wheel)		2/1 x+2	2/1 x+2	2/1 x+2
3.6 Wheel tread, drive side	b10 (mm)	680	680	680
3.7 Wheel tread, load side	b11 (mm)	964	1064	1064
Size				
4.1 Fork tilt	α / β (°)	3/5	3/5	3/5
4.2 Mast closed height	h1 (mm)	2082	2142	2082
4.3 Free lift height	h2 (mm)	400	1542	80
4.4 Lift height	h3 (mm)	3000	4500	3000
4.5 Mast extended height with load-backrest	h4 (mm)	3960	5460	3960
4.6 Overhead guard height	h6 (mm)	2250	2250	2250
4.7 Stand board height	h7 (mm)	300	300	300
4.8 Overall length	l1 (mm)	2258	2283	2299
4.9 Overall width	b1/b2 (mm)	1090	1090 /1170	1090/1170
4.10 Fork size	l/e/s (mm)	1070 /100 /35	1070 /100 /35	1070/122/40
4.11 Fork carriage width	b3 (mm)	1088	1088	1088
4.12 Fork outside width	b5 (mm)	222 -650	222 -750	244-772
4.13 Inner leg width	b4 (mm)	750	856	856
4.14 Reach stroke	l4 (mm)	550	525	717
4.15 Mast ground clearance	m1 (mm)	82	82	82
4.16 Aisle width for pallet 1000*1200mm(C=500mm)	Ast (mm)	2663	2681	2746
4.17 Aisle width for pallet 800*1200mm(C=600mm)	Ast (mm)	2714	2737	2764
4.18 Turning radius	Wa (mm)	1594	1594	1784
Function				
5.1 Driving speed(load/unload)	km /h	9/10	9/10	9/10
5.2 Lifting speed(load/unload)	mm /s	240/400	200/350	220/380
5.3 Lowering speed(load/unload)	mm /s	300/270	320/280	310/260
5.4 Max. gradeability(load/unload)(S2-5min)	%(tan θ)	≤10	≤10	≤10
5.5 Brake type		Mechanical	Mechanical	Mechanical
Drive				
6.1 Driving motor(S2-60min)	kw	4.5	4.5	4.5
6.2 Lifting motor(S3-15%)	kw	7.5	7.5	7.5
6.3 Battery voltage/capacity	V/Ah	48/300	48/300	48/300
6.4 Battery weight	kg	500	500	500
6.5 Steering system		EPS	EPS	EPS
Other				
7.1 Battery replacement type		Side pull	Side pull	Side pull
7.2 Lithium battery voltage/capacity (optional)	V/Ah	48/270	48/270	48/270

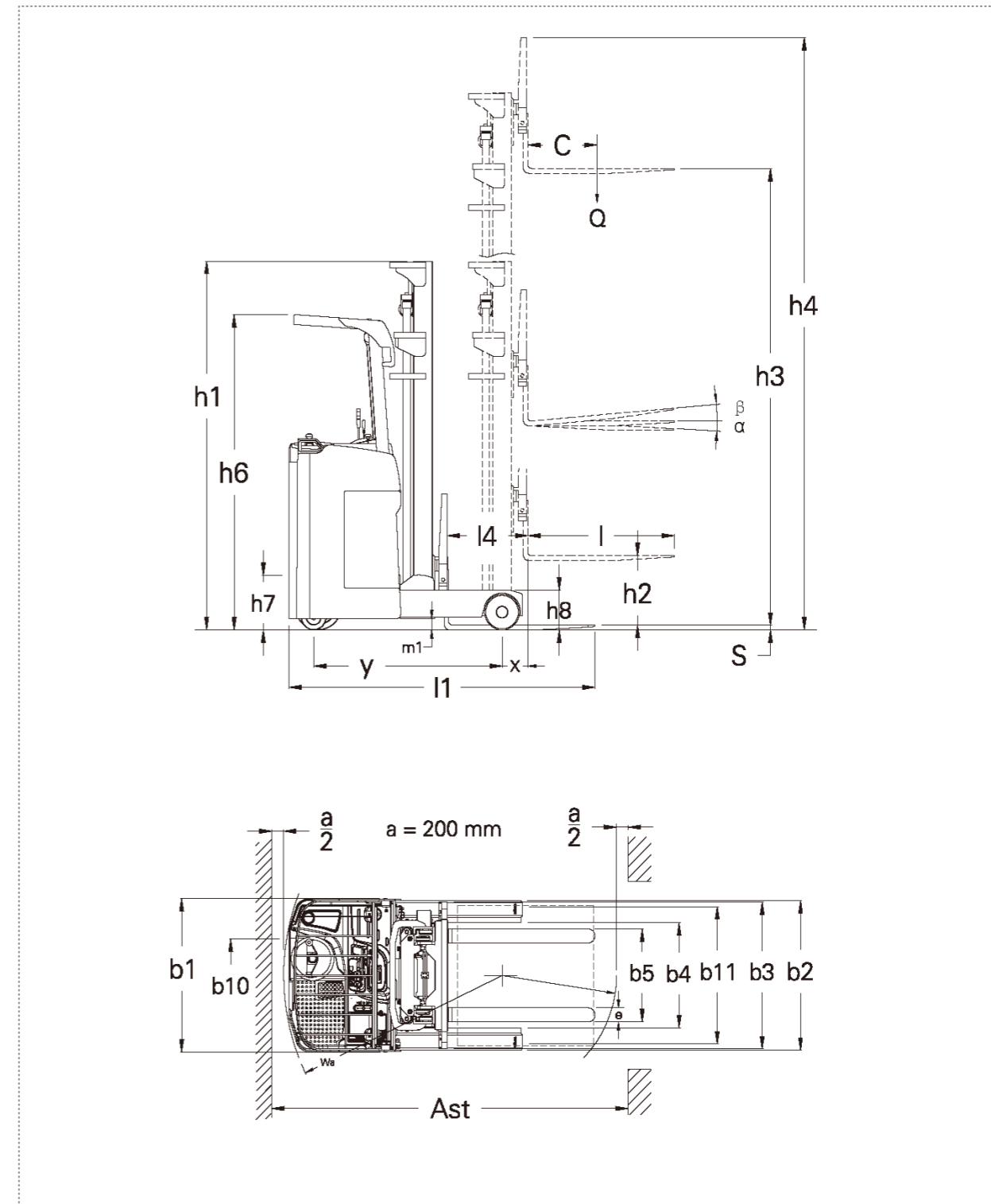

Standard					
1.1 Brand		MIMA	MIMA	MIMA	MIMA
1.2 Model		MF25	MF25	MF30	MF30
1.3 Power type		(Duplex mast) Battery	(Triplex full free mast) Battery	(Duplex mast) Battery	(Triplex full free mast) Battery
1.4 Operation type		Stand on	Stand on	Stand on	Stand on
1.5 Rated capacity	Q (kg.)	2500	2500	3000	3000
1.6 Load center	C (mm)	500	500	500	500
1.7 Front overhang	x (mm)	180	180	180	180
1.8 Wheelbase	y (mm)	1720	1720	1920	1920
Weight					
2.1 Service weight (incl. battery)	kg	3300	3580	3400	3680
2.2 Axle capacity with no load, drive side/load side	kg	/	/	/	/
2.3 Axle capacity with full load when fork forward, drive side/load side	kg	/	/	/	/
2.4 Axle capacity with full load when fork backward, drive side/load side	kg	/	/	/	/
Wheel					
3.1 Wheel type		PU	PU	PU	PU
3.2 Load wheel	mm	Φ 267×135	Φ 267×135	Φ 267×135	Φ 267×135
3.3 Drive wheel	mm	Φ 380×165	Φ 380×165	Φ 380×165	Φ 380×165
3.4 Auxiliary wheel	mm	Φ 204×76	Φ 204×76	Φ 204×76	Φ 204×76
3.5 Number of wheels, front/rear(x=drive wheel)		2/1 x+2	2/1 x+2	2/1 x+2	2/1 x+2
3.6 Wheel tread, drive side	b10 (mm)	725	725	725	725
3.7 Wheel tread, load side	b11 (mm)	1135	1135	1135	1135
Size					
4.1 Fork tilting	α / β (°)	3/5	2/6	3/5	2/6
4.2 Mast closed height	h1 (mm)	2082	2292	2082	2292
4.3 Free lift height	h2 (mm)	80	1550	80	1550
4.4 Lift height	h3 (mm)	3000	4500	3000	4500
4.5 Mast extended height with load-backrest	h4 (mm)	3960	5460	4050	5550
4.6 Overhead guard height	h6 (mm)	2300	2300	2300	2300
4.7 Stand board height	h7 (mm)	350	350	350	350
4.8 Overall length	l1 (mm)	2387	2434	2487	2534
4.9 Overall width	b1/b2 (mm)	1190/1270	1190/1270	1190/1270	1190/1270
4.10 Fork size	l/e/s (mm)	1070/122/40	1070/122/40	1070/125/45	1070/125/45
4.11 Fork carriage width	b3 (mm)	1088	1088	1148	1148
4.12 Fork outside width	b5 (mm)	244-772	244-772	250-750	250-750
4.13 Inner leg width	b4 (mm)	892	892	892	892
4.14 Reach stroke	l4 (mm)	825	775	925	875
4.15 Mast ground clearance	m1 (mm)	82	82	82	82
4.16 Aisle width for pallet 1000*1200mm(C=500mm)	Ast (mm)	2894	2919	3045	3066
4.17 Aisle width for pallet 800*1200mm(C=600mm)	Ast (mm)	2882	2921	3000	3037
4.18 Turning radius	Wa (mm)	1995	1995	2192	2192
Function					
5.1 Driving speed (load/unload)	km /h	9/10	9/10	8/10	8/10
5.2 Lifting speed (load/unload)	mm /s	240/320	220/300	220/320	200/300
5.3 Lowering speed (load/unload)	mm /s	340/290	310/260	340/290	310/260
5.4 Max. gradeability (load/unload) (S2-5min)	% (tan θ)	≤10	≤10	≤10	≤10
5.5 Brake type		Mechanical	Mechanical	Mechanical	Mechanical
Drive					
6.1 Driving motor (S2-60min)	kw	5.5	5.5	5.5	5.5
6.2 Lifting motor (S3-15%)	kw	8.6	8.6	8.6	8.6
6.3 Battery voltage/capacity	V/Ah	48/400	48/400	48/400	48/400
6.4 Battery weight	kg	650	650	650	650
6.5 Steering system		EPS	EPS	EPS	EPS
Other					
7.1 Battery replacement type		Side pull	Side pull	Side pull	Side pull
7.2 Lithium battery voltage/capacity (optional)	V/Ah	48/300	48/300	48/300	48/300

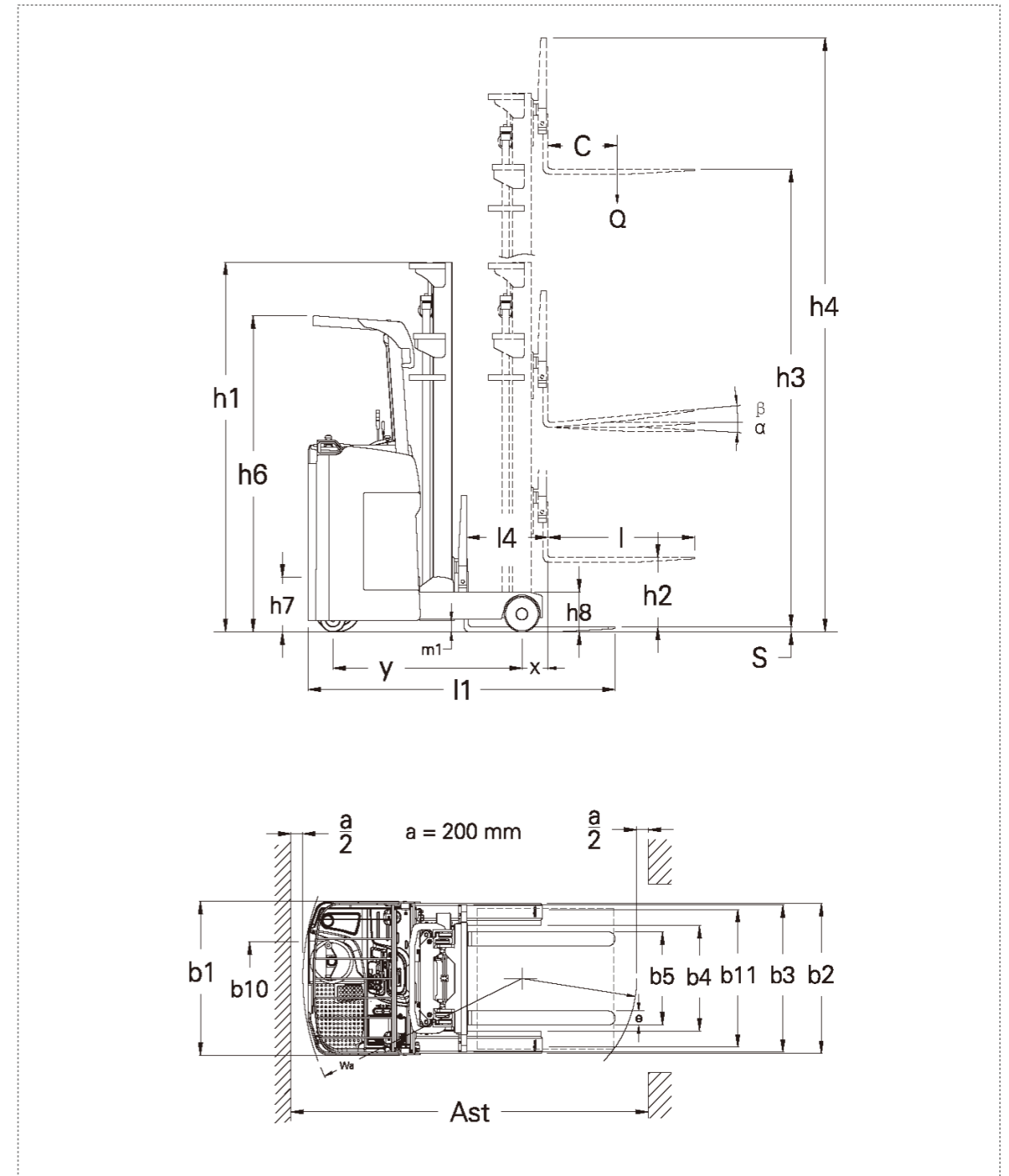

Duplex mast		MF12			
Model	MF	12-30	12-35	12-40	12-45
Lift height	h3(mm)	3000	3500	4000	4500
Mast extended height with load-backrest	h4(mm)	3960	4460	4960	5460
Mast closed height	h1(mm)	2080	2330	2630	2880

Triplex full free mast		MF12			
Model	MF	12-45	12-50	12-55	12-60
Lift height	h3(mm)	4500	5000	5500	6000
Mast extended height with load-backrest	h4(mm)	5455	5955	6455	6955
Mast closed height	h1(mm)	2080	2247	2413	2580
Free lift height	h2(mm)	1480	1647	1813	1980

Duplex mast		MF15				MF15D			
Model	MF	15-30	15-35	15-40	15-45	15D-30	15D-35	15D-40	15D-45
Lift height	h3(mm)	3000	3500	4000	4500	3000	3500	4000	4500
Mast extended height with load-backrest	h4(mm)	3960	4460	4960	5460	3960	4460	4960	5460
Mast closed height	h1(mm)	2082	2332	2632	2882	2080	2330	2630	2880
Free lift height	h2(mm)	400	400	400	400	0	0	0	0

Triplex full free mast		MF15D	
Model	MF	15D-45	15D-50
Lift height	h3(mm)	4500	5000
Mast extended height with load-backrest	h4(mm)	5455	5955
Mast closed height	h1(mm)	2080	2247
Free lift height	h2(mm)	1480	1647

Triplex full free mast		MF15							
Model	MF	15-45	15-50	15-55	15-60	15-65	15-70	15-72	15-75
Lift height	h3(mm)	4500	5000	5500	6000	6500	7000	7200	7500
Mast extended height with load-backrest	h4(mm)	5460	5960	6460	6960	7460	7960	8160	8460
Mast closed height	h1(mm)	2142	2309	2475	2642	2809	2975	3042	3142
Free lift height	h2(mm)	1542	1709	1875	2042	2209	2375	2442	2542

Duplex mast		MF20				MF25			
Model	MF	20-30	20-35	20-40	20-45	25-30	25-35	25-40	25-45
Lift height	h3(mm)	3000	3500	4000	4500	3000	3500	4000	4500
Mast extended height with load-backrest	h4(mm)	3960	4460	4960	5460	3960	4460	4960	5460
Mast closed height	h1(mm)	2082	2332	2632	2882	2082	2332	2632	2882
Free lift height	h2(mm)	80	80	80	80	80	80	80	80

Triplex full free mast		MF20							
Model	MF	20-45	20-50	20-55	20-60	20-65	20-70	20-72	20-75
Lift height	h3(mm)	4500	5000	5500	6000	6500	7000	7200	7500
Mast extended height with load-backrest	h4(mm)	5460	5960	6460	6960	7460	7960	8160	8460
Mast closed height	h1(mm)	2142	2309	2475	2642	2809	2975	3042	3142
Free lift height	h2(mm)	1542	1709	1875	2042	2209	2375	2442	2542

Triplex full free mast		MF25								
Model	MF	25-45	25-50	25-55	25-60	25-65	25-70	25-72	25-75	25-80
Lift height	h3(mm)	4500	5000	5500	6000	6500	7000	7200	7500	8000
Mast extended height with load-backrest	h4(mm)	5460	5960	6460	6960	7460	7960	8160	8460	8960
Mast closed height	h1(mm)	2292	2459	2625	2792	2959	3125	3192	3292	3559
Free lift height	h2(mm)	1550	1716	1884	2050	2216	2384	2450	2550	2816

Duplex mast		MF30			
Model	MF	30-30	30-35	30-40	30-45
Lift height	h3(mm)	3000	3500	4000	4500
Mast extended height with load-backrest	h4(mm)	4050	4550	5050	5550
Mast closed height	h1(mm)	2082	2332	2632	2882
Free lift height	h2(mm)	80	80	80	80

Triplex full free mast		MF30								
Model	MF	30-45	30-50	30-55	30-60	30-65	30-70	30-72	30-75	30-80
Lift height	h3(mm)	4500	5000	5500	6000	6500	7000	7200	7500	8000
Mast extended height with load-backrest	h4(mm)	5550	6050	6550	7050	7550	8050	8250	8550	9050
Mast closed height	h1(mm)	2292	2459	2625	2792	2959	3125	3192	3292	3559
Free lift height	h2(mm)	1550	1716	1884	2050	2216	2384	2450	2550	2816

